

Centrality determination in BM@N at NICA: Using forward fragments

Sergey Morozov
on behalf of INR RAS, Moscow



Centrality determination in BM@N at NICA

BM@N experiment at NICA acceleration complex

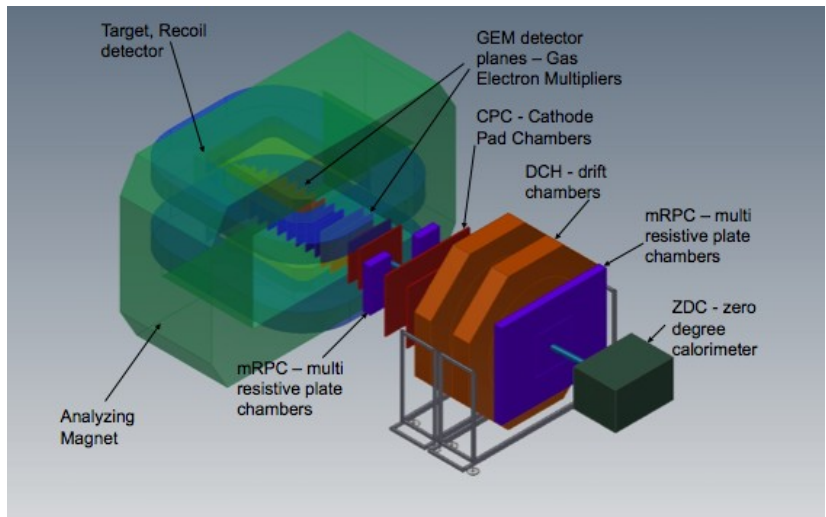
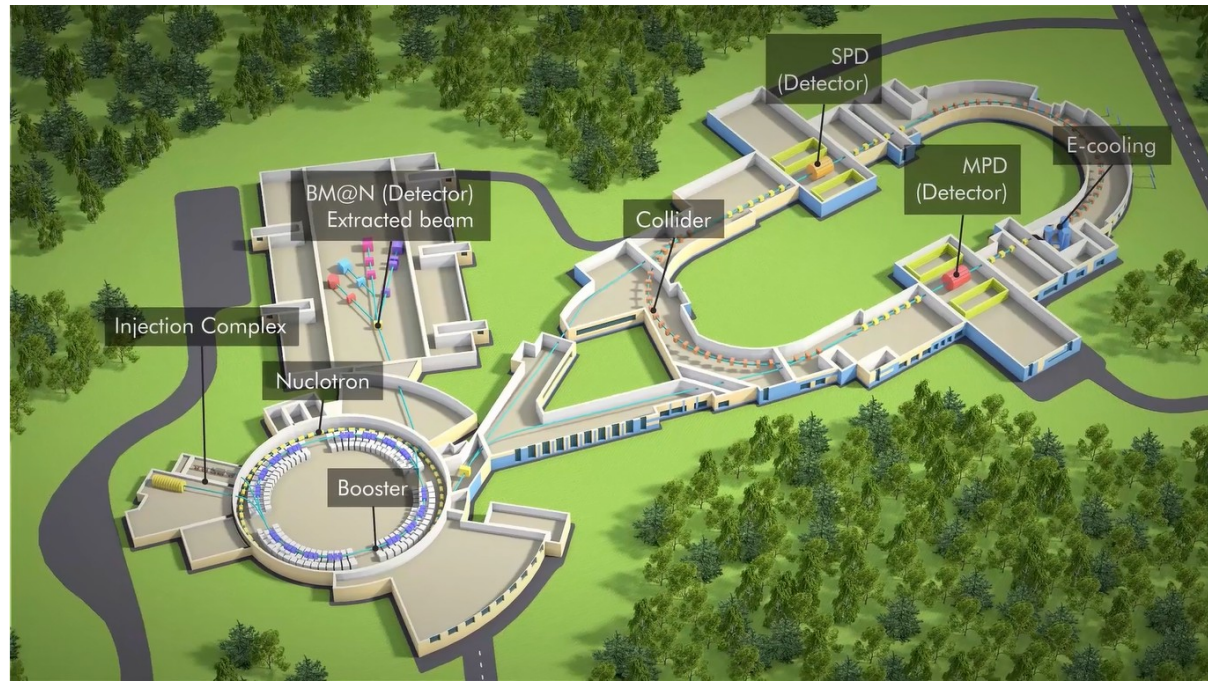

Ar @ 3.2AGeV

Year	2016	2017 spring	2018 spring	2021	2022 and later
Beam	d(↑)	C	Ar, Kr, C(SRC)	Kr, Xe	up to Au
Max.intensity, Hz	0.5M	0.5M	0.5M	0.5M	2-5M
Trigger rate, Hz	5k	5k	10k	10k	20k→50k

C+C @ 4AGeV

24-28 August 2020

Workshop on analysis techniques for centrality determination and flow measurements at FAIR and NICA

Zero Degree Calorimeter (ZDC) at BM@N



ZDC modules

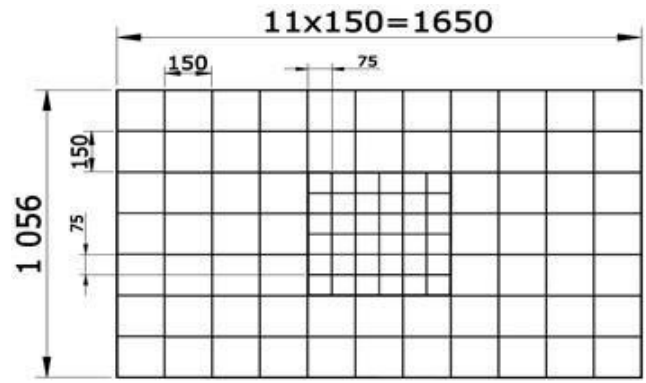

Central part with 36 modules 7.5 x 7.5cm²
Outer part with 68 modules 15 x 15cm²

ZDC module structure

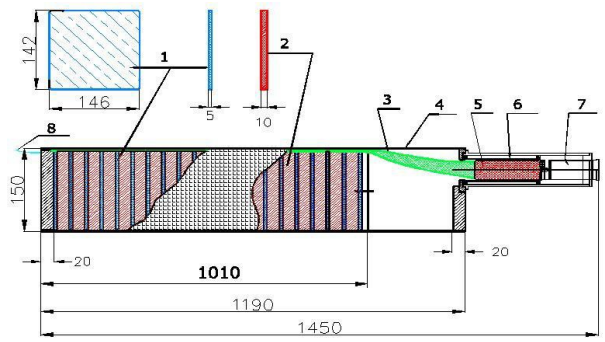

- ZDC modules based on old technologies of light collection by WLS plate and does not have a longitudinal segmentation.
- calibration: on cosmics only

64 layers of 5mm scint. + 10mm Pb

Centrality determination in BM@N at NICA

Experimental data:

- single ion selection:
 - 1) $nHits_{BC2} = 1, nHits_{T0} = 1$
 - 2) no fake trigger: $nHits_{VETO} = 0$

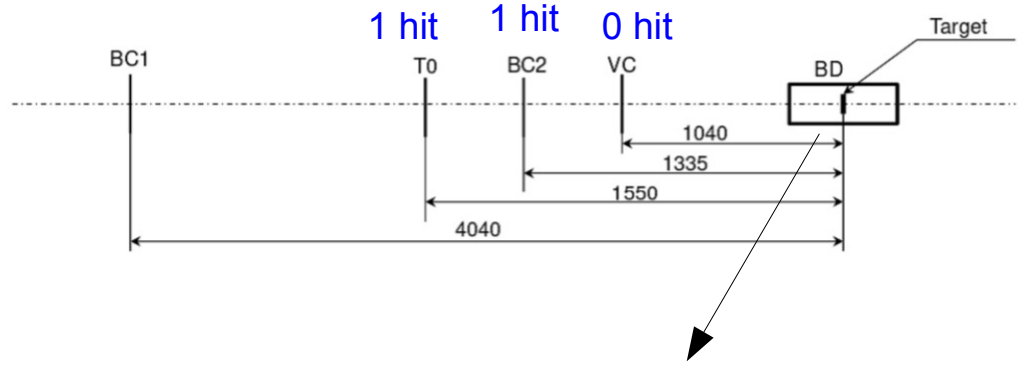

Simulation in GEANT4:

- all detectors in place (TOF + DCH)
- DCM-QGSM model, C+C@4 AGeV reaction
- event selection with BD detector ($nHits_{BD} \geq 2$)

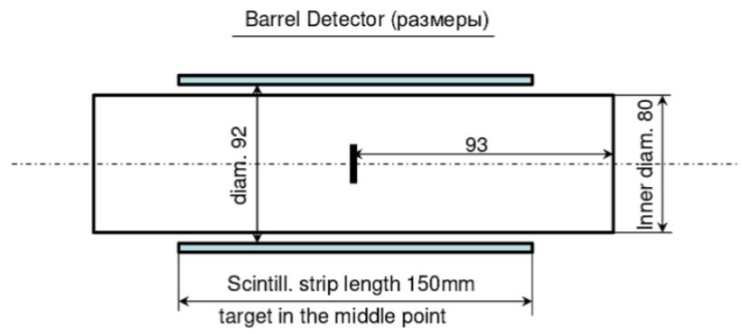

experimental data

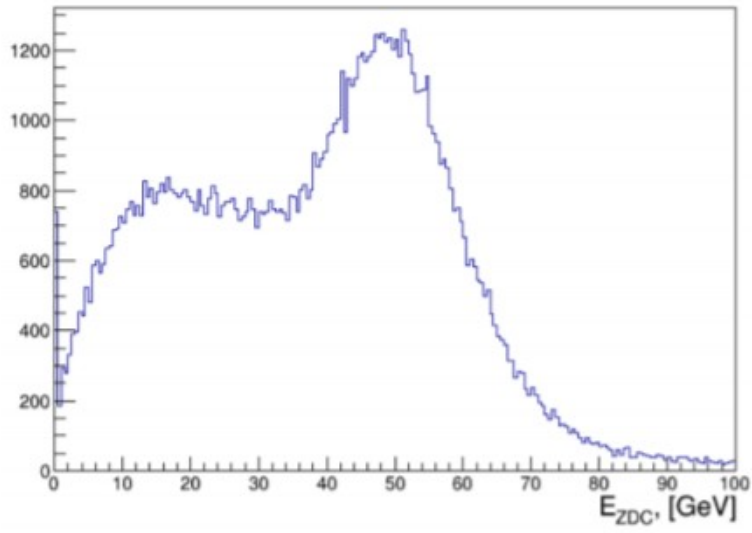

simulation

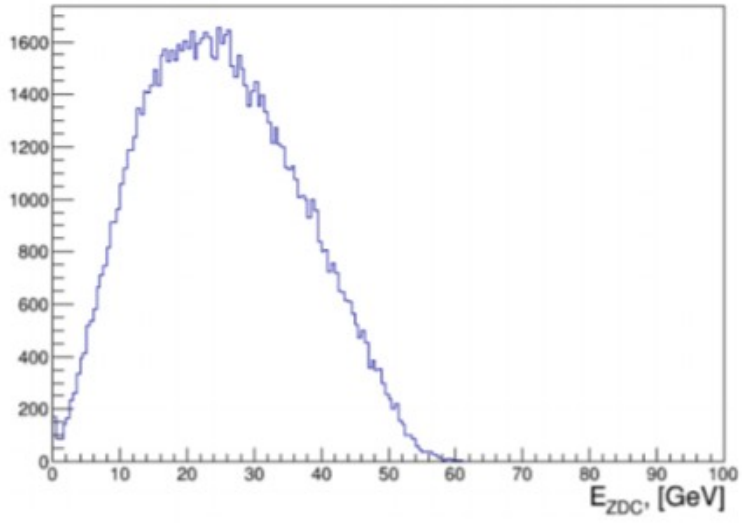

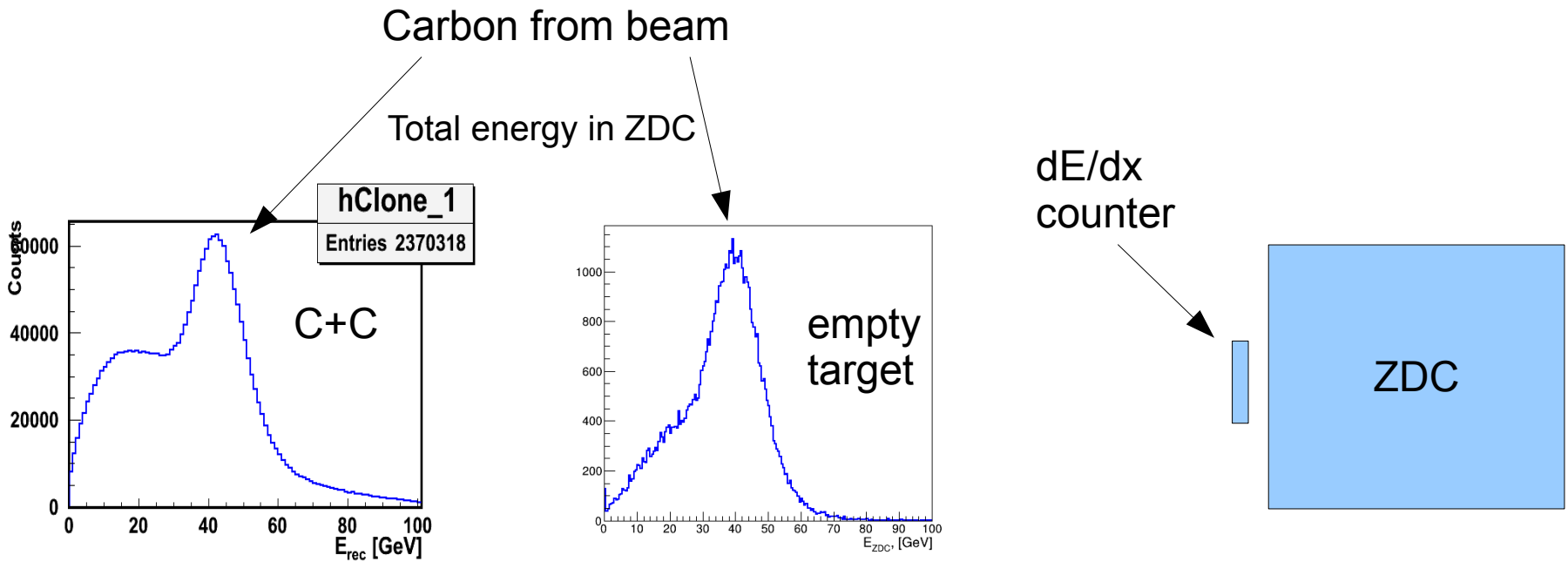

Trying to reject the C ions..

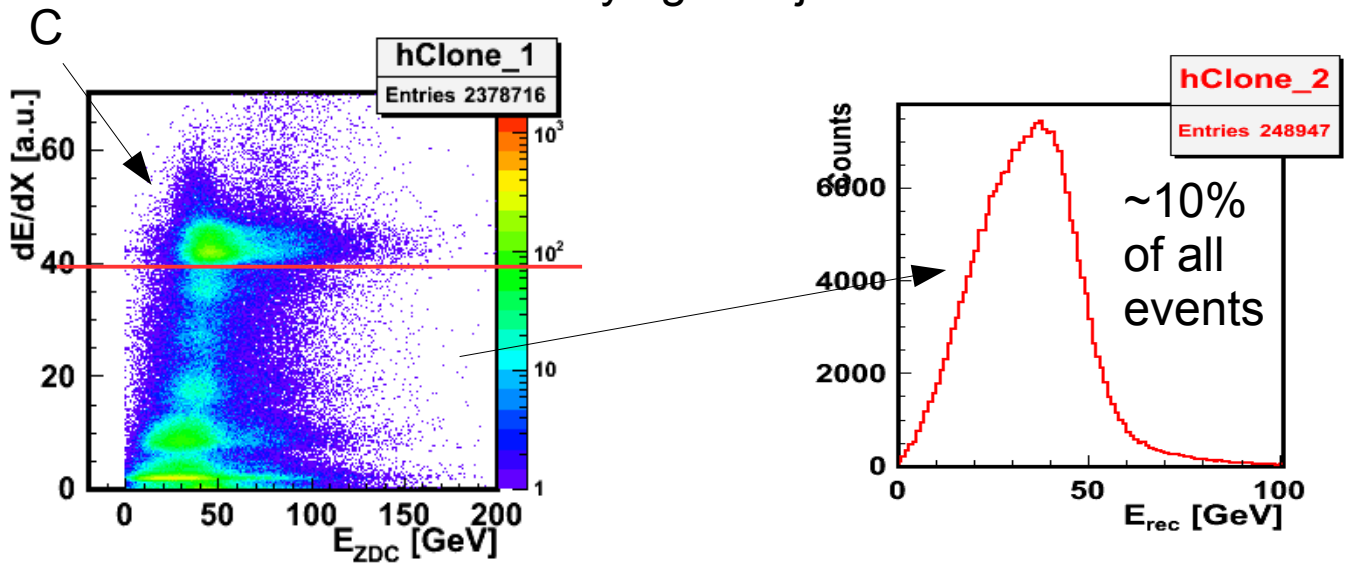

1) Exp. data (events selected with dE/dx counter)

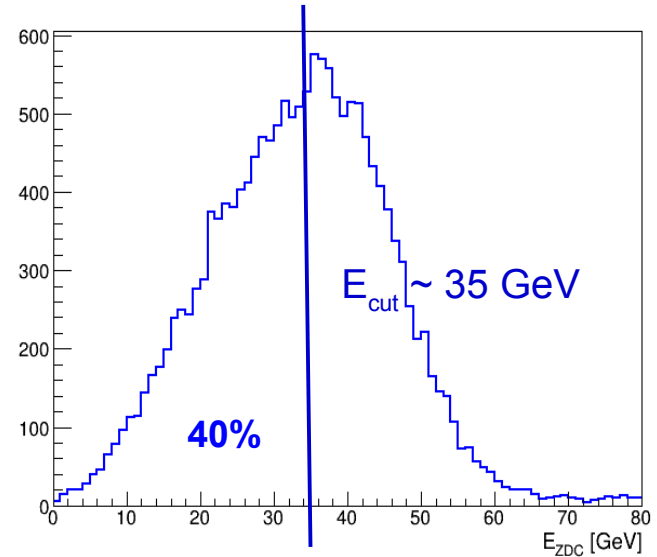

“Centrality” 0 - 40% → $E_{cut} \sim 35$ GeV

(NOTE: this is not true centrality of all MB events! This is 0-40% of centrality for specially selected events)

2) Comparison with simulation

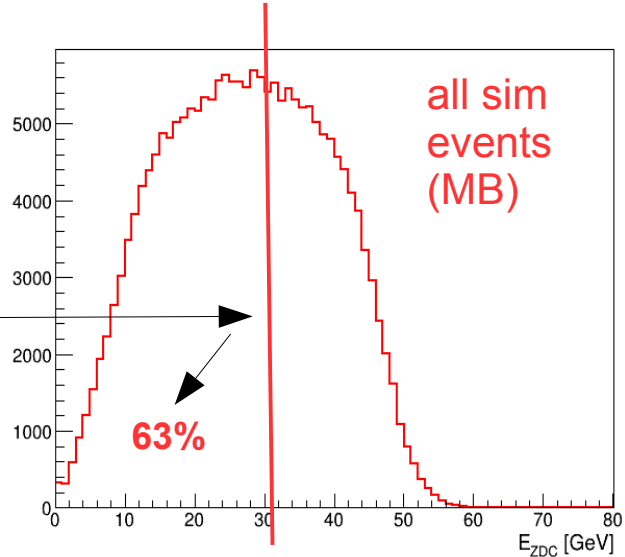
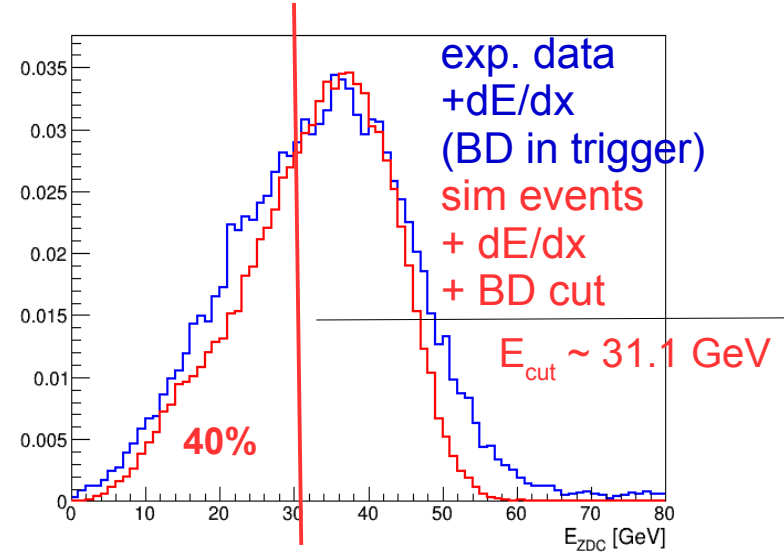

Centrality in simulation

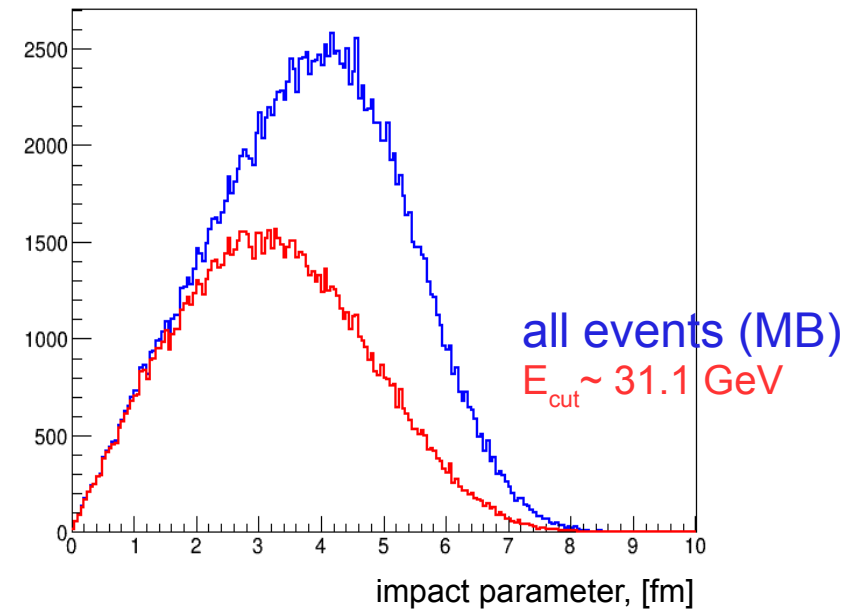
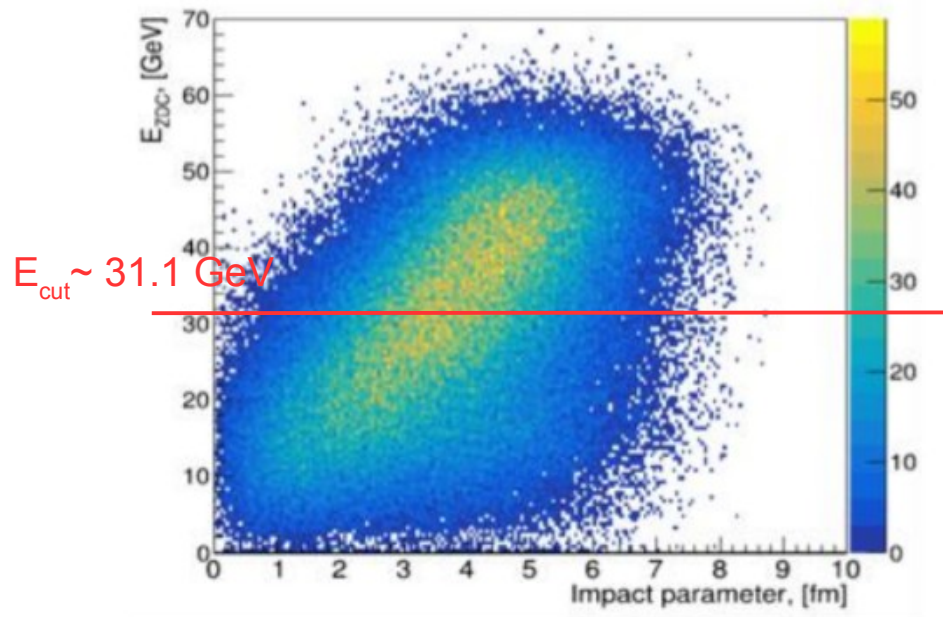

- low energy + small number of nucleons \rightarrow wide b distribution after the cut

Centrality selection for all experimental data with C beam contamination :

→ energy asymmetry method

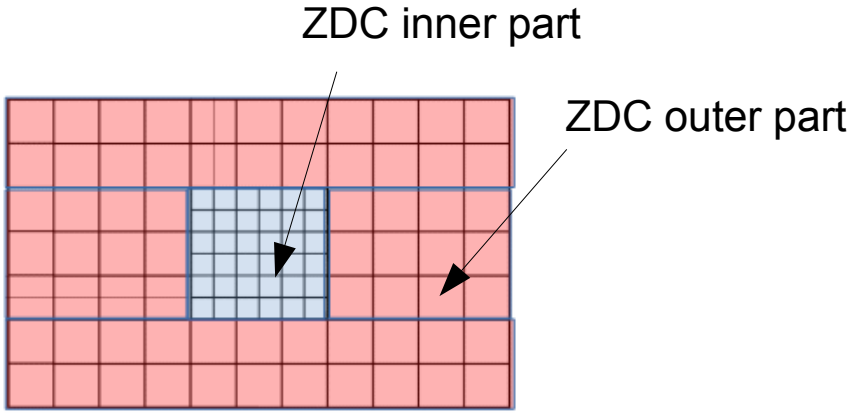

$$Energy\ asymmetry = \frac{E_{ZDC\ inner} - E_{ZDC\ outer}}{E_{ZDC\ inner} + E_{ZDC\ outer}}$$

events with C beam ions

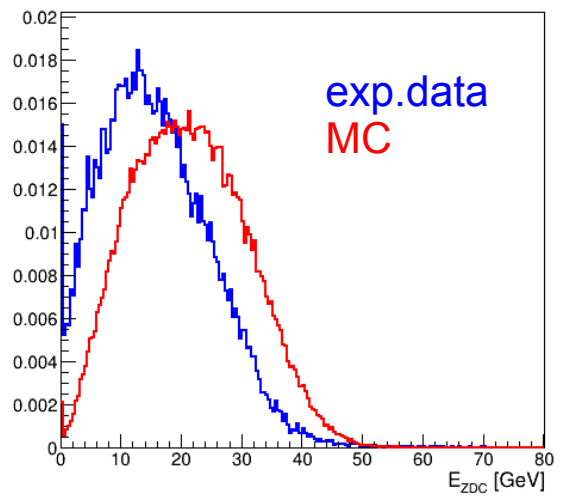
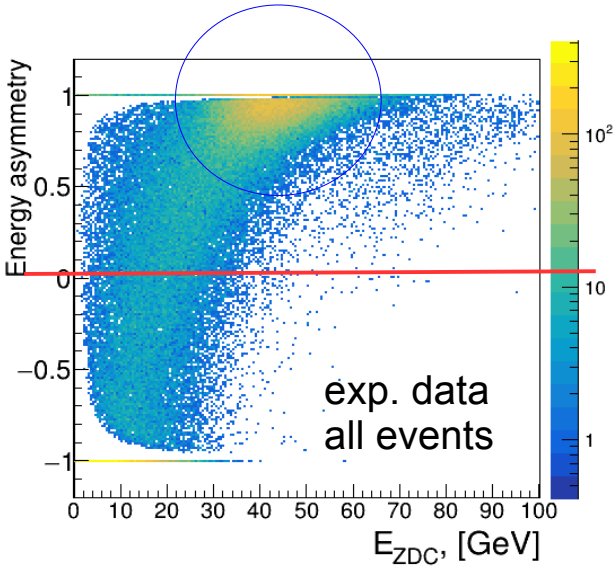
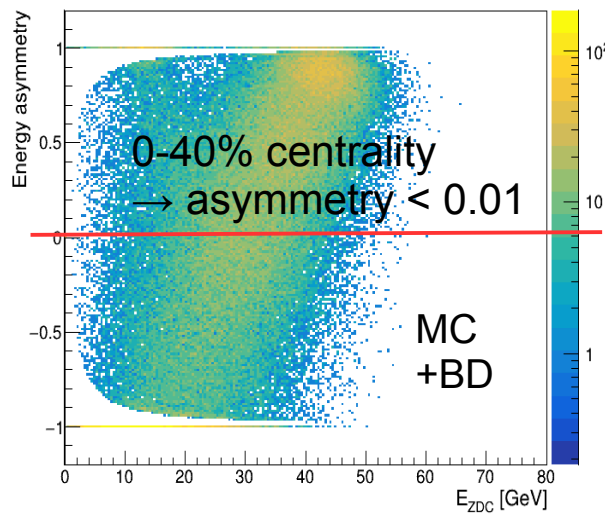

Comparing (in MC) of two methods for centrality selection:

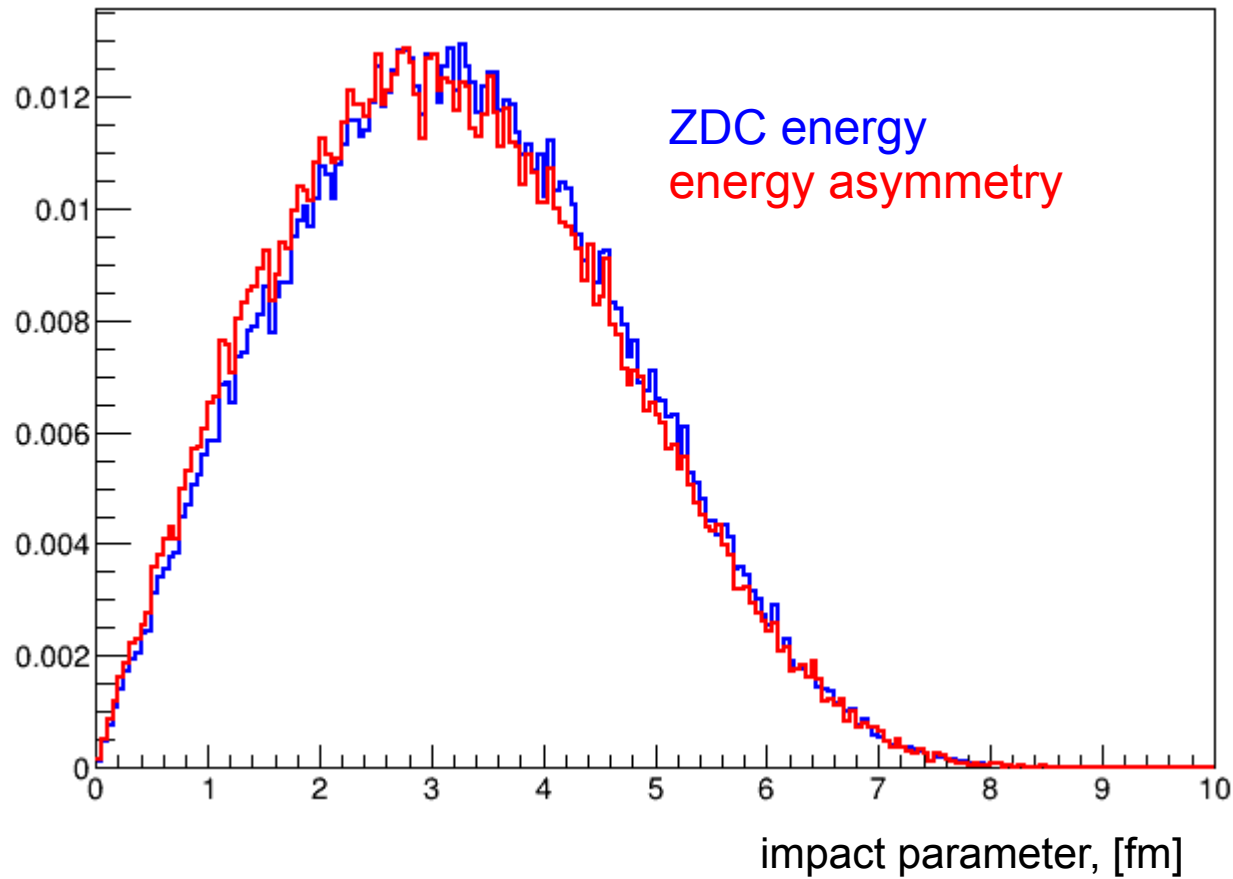

..quite good agreement

BM@N Run 7, Spring 2018
Ar 3.2 AGeV \rightarrow Al

GEANT4, LAQGSM mb, (~300k ev.)

Run 3842, 3843, 3847, 3850 (~600k ev.)

ZDC energy, GeV

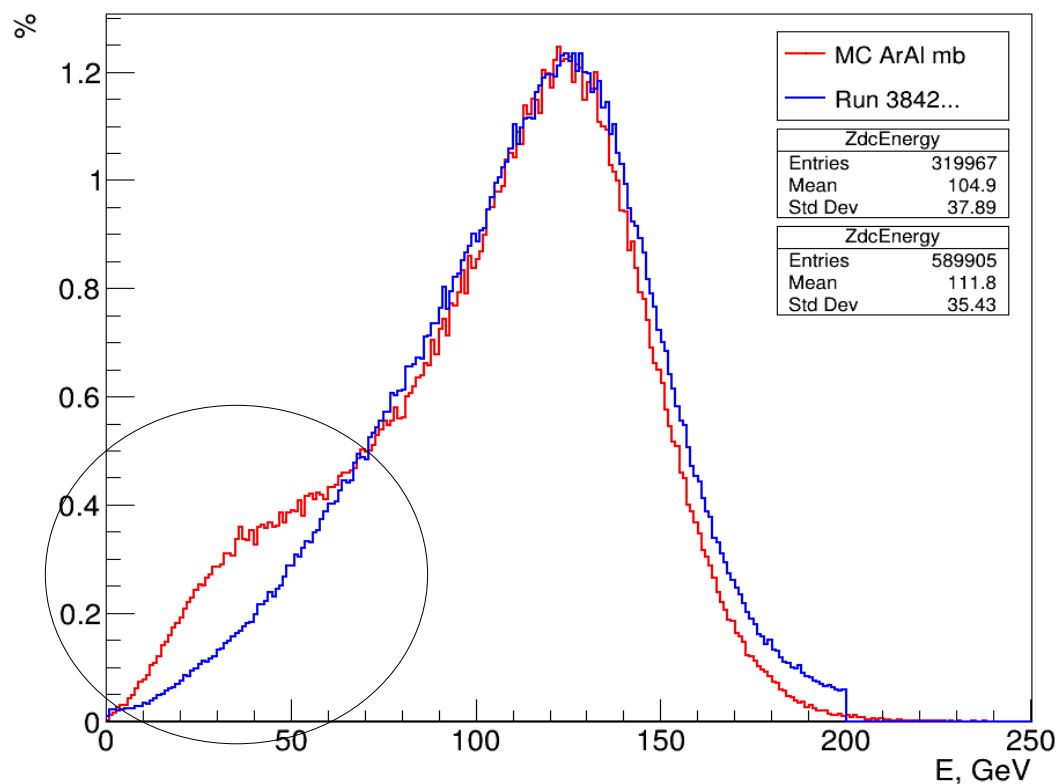

Thresholds and scale was tuned for best match. Settings differ for large and small modules.

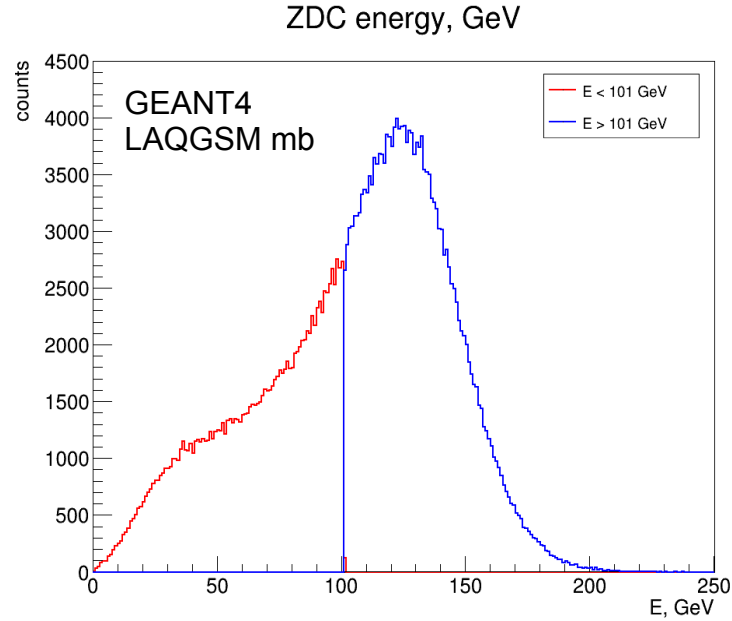

40% of events with smallest energy in MC are placed below 101 GeV

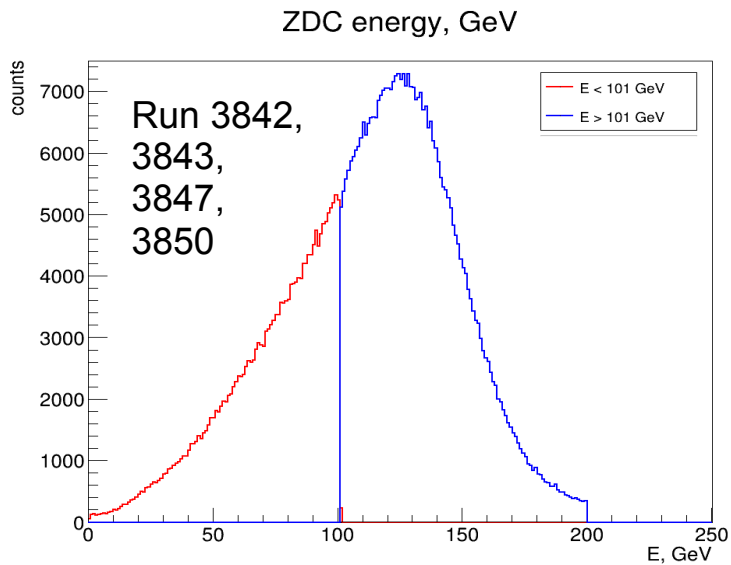
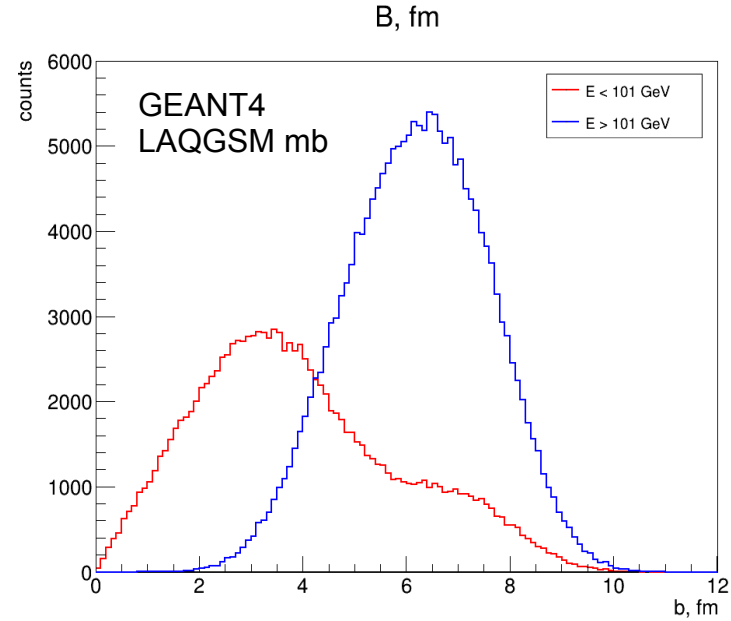

35% of events has energy below 101 GeV in exp. data

Next steps:

- data reconstruction improvement
- test of several MC models

Conclusions:

- centrality estimation was done for C+C @ 4A GeV in BM@N experiment
- two methods for centrality determination have been used:
 - 1) full energy in forward hadron calorimeter (ZDC)
 - 2) energy asymmetry in ZDC
- first comparison data and MC was done for Ar beam at BM@N

Outlook:

- Machine Learning (ML) technique will be proposed for centrality estimation and effective carbon event rejection

Thank you for your attention!

This work was supported by the RFBR 18-02-40065 mega grant